

|   |      |     |      |    |                                    |   |   |   |
|---|------|-----|------|----|------------------------------------|---|---|---|
| 8 | 7    | 6   | 5    | 4  | 3                                  | 2 | 1 |   |
| J | REV. | ECO | DATE | BY | REVISION DESCRIPTION               |   |   | J |
|   |      |     |      |    | Last Development revision was R01. |   |   |   |

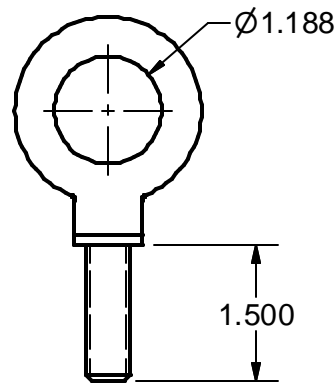
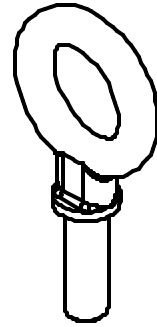

**DESCRIPTION:** 1/2 X 1.5 DROP FORGED STEEL, SHOULDER PATTERN EYE BOLT  
**THREAD:** 1/2-13 UNC-2A (FULL THREAD)  
**RATED CAPACITY:** 2,400 (LBS.)  
**FINISH:** NONE  
**APPROVED SUPPLIER:** KEN FORGING INC.  
 CATALOG # K2025 (OR EQUIVALENT)

REFER TO DESIGN INTENT DOCUMENT PRIOR TO REVISING DOCUMENT OR SUBSTITUTING MATERIAL

|               |  |  |                 |         |       |     |       |     |      |             |  |     |         |  |
|---------------|--|--|-----------------|---------|-------|-----|-------|-----|------|-------------|--|-----|---------|--|
| B             | THIRD ANGLE<br>GENERAL TOLERANCE SPEC.<br>N/A<br>NORMAL CLASS TOLERANCE  | <b>SQUARE D</b><br>Schneider Electric  |                 |         |       |     |       |     |      |             |  |     |         |  |
|               | DIMENSIONS ARE IN INCHES UNLESS OTHERWISE NOTED<br>* OR (S) * DENOTES CRITICAL CHARACTERISTIC  |  | <b>EYE BOLT</b> |         |       |     |       |     |      |             |  |     |         |  |
|               | <small>SQUARE D/SCHNEIDER ELECTRIC HAS PROPRIETARY RIGHTS TO THE INFORMATION CONTAINED HEREON. THIS INFORMATION REMAINS THE PROPERTY OF SQUARE D/SCHNEIDER ELECTRIC AND MAY BE REPRODUCED OR USED ONLY IN ACCORDANCE WITH INSTRUCTIONS OR PERMISSION FROM SQUARE D/SCHNEIDER ELECTRIC. THIS DOCUMENT SHALL BE RETURNED TO SQUARE D/SCHNEIDER ELECTRIC UPON REQUEST. USER SHOULD VERIFY DRAWINGS ARE THE MOST RECENT VERSION PRIOR TO USE. © 2006, SCHNEIDER ELECTRIC, ALL RIGHTS RESERVED.</small> | <table border="1"> <tr> <td>DRW</td> <td>CLE</td> <td>CHK</td> <td>CTY</td> <td>SCALE</td> <td>NTS</td> </tr> <tr> <td>DATE</td> <td colspan="2">30 AUG 2006</td> <td>ECO</td> <td colspan="2">06G0264</td> </tr> </table> | DRW             | CLE     | CHK   | CTY | SCALE | NTS | DATE | 30 AUG 2006 |  | ECO | 06G0264 |  |
|               | DRW  | CLE  | CHK             | CTY     | SCALE | NTS |       |     |      |             |  |     |         |  |
| DATE          | 30 AUG 2006  |  | ECO             | 06G0264 |       |     |       |     |      |             |  |     |         |  |
| SIZE <b>A</b> | DWG NO <b>80123-096-01</b>   | SHEET <b>1 OF 1</b>  |                 |         |       |     |       |     |      |             |  |     |         |  |

PRINTS TO: Loc1, Loc2, Loc3