

8 7 6 5 4 3 2 1

REVISIONS			
REV.	DESCRIPTION	DATE	APPROVED
A	PROTOTYPE RELEASE	7/17/2020	ABE

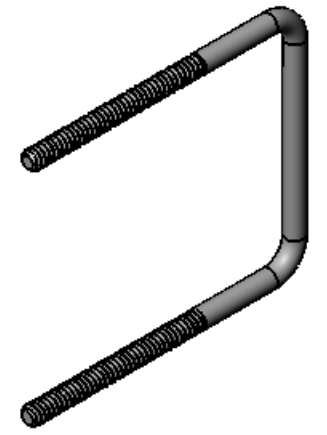
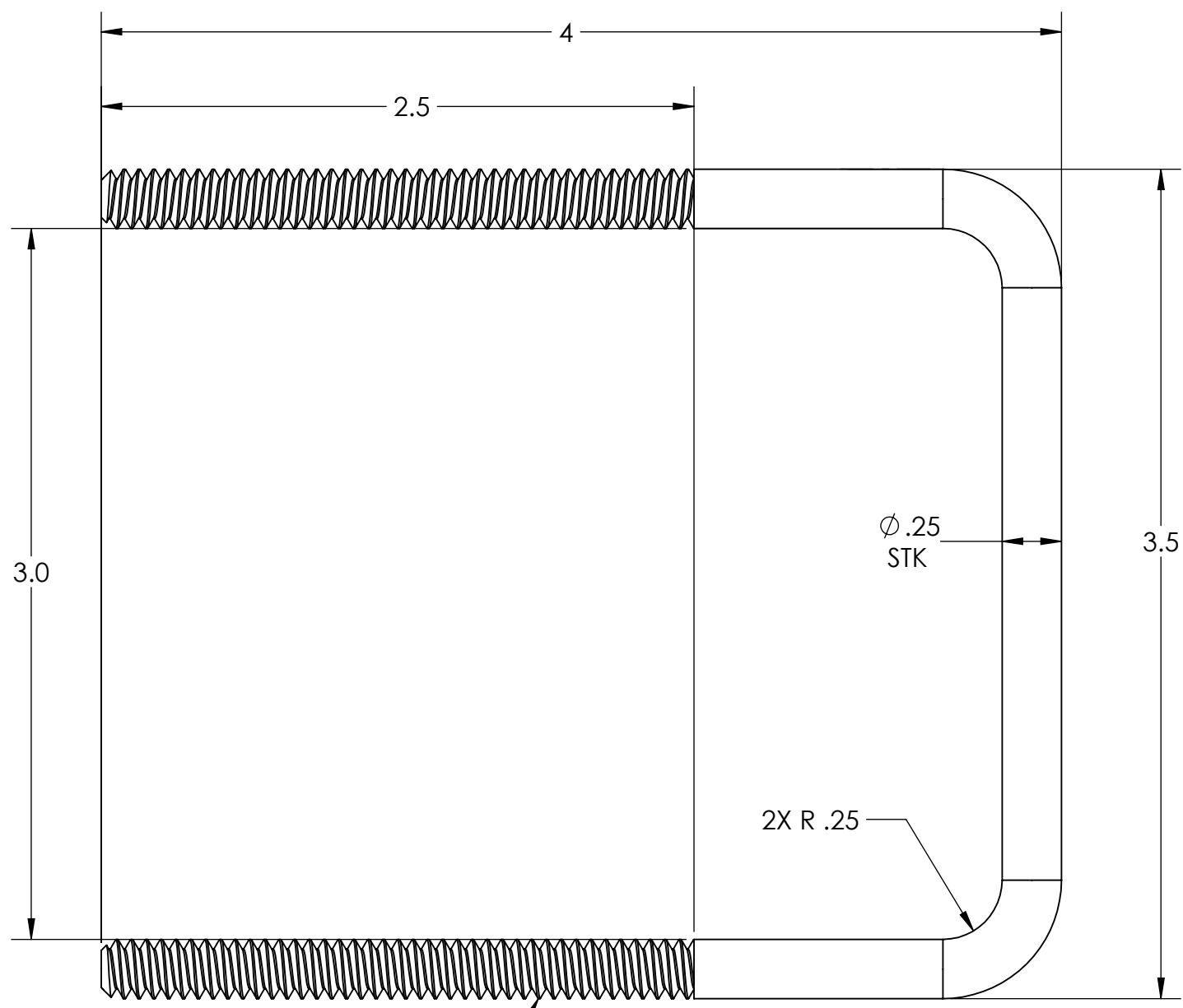

D
C
B
A

D
C
B
A

THD 1/4-20

2X R .25

Ø.25
STK

UNLESS OTHERWISE SPECIFIED:

DIMENSIONS ARE IN INCHES
TOLERANCES:
FRACTIONAL ±
ANGULAR: MACH ±.5° BEND ±.5°
TWO PLACE DECIMAL ±.01
THREE PLACE DECIMAL ±.003

INTERPRET GEOMETRIC TOLERANCING PER:

MATERIAL
STAINLESS STEEL

FINISH
-

DO NOT SCALE DRAWING

	NAME	DATE
DRAWN	L. B.	07/17/20
CHECKED	ABE	07/17/20
ENG APPR.		
MFG APPR.		
Q.A.		

COMMENTS:

TITLE:

BOLT SQUARE

SIZE

DWG. NO.

REV

SCALE:

WEIGHT:

SHEET 1 OF 1

PROPRIETARY AND CONFIDENTIAL
THE INFORMATION CONTAINED IN THIS DRAWING IS THE SOLE PROPERTY OF ABE. ANY REPRODUCTION IN PART OR AS A WHOLE WITHOUT THE WRITTEN PERMISSION OF THE ABE IS PROHIBITED.

8 7 6 5 4 3 2 1